

H&F Manufacturing Corp.

Asbestos 177 Installation

Profile Dimensions:

Table 1

Distance Between Corrugations (in.)	Wave Depth (in.)	Width (in.)	# of Corrugations	Effective Width (in.)	Wave Overlap	Percent Overlap
7	2	36.25	5-1/4	34.85	1/4	3.8
7	2	43.30	6-1/4	41.80	1/4	3.4
7	2	43.30	6-1/4	34.85	1-1/4	19.5

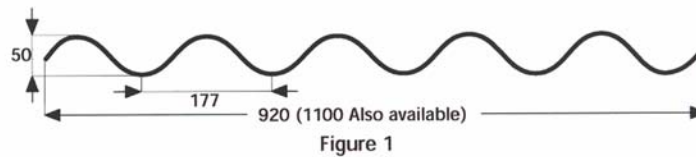
Figure 1

Distance Between Purlins:

Table 2

Sheet Thickness	Theoretical Weight (psf)	Load (psf)	Distance Between Roof Purlins (in.)	Distance Between Wall Purlins (in.)
1/32"	.30	10.24	49.22	57.09
		16.39	45.28	53.15
		22.53	43.31	49.22

1. The dimensions depicted above do not supersede the requirements of local construction codes. The distance depicted above are based on the structural properties with the following factors being taken into consideration: sheet deflection, potential wind load, snow load, hail, and other applicable loads according to usual construction practice
2. When designing a new roof, it is strongly recommended that the slope be above 10%. The recommended maximum sheet length is 23'. In case of minimal recommended slope or below, or in case of extreme weather conditions (excessive rain and/or wind.) The larger overlap of 1-1/2 corrugations is recommended.
3. The recommended maximum distance between supports at the edge and first purlin is 35 inches, or the value dictated by the design engineer. (See figure 4)
4. In case of repairing existing asbestos roof, when a new H&F sheet will replace the old, damaged asbestos one, the purlin distance should not surpass 49.22" under any circumstances.

Positioning of Sheets:

1. The sheets should be laid down on the roof against the primary direction of rain. (See Figure 2)
2. Stepping ladders and other devices required for safe work should be used.
3. **Do not step on the sheets between purlins.**
4. Never leave sheets untended until all the required screws have been properly tightened.

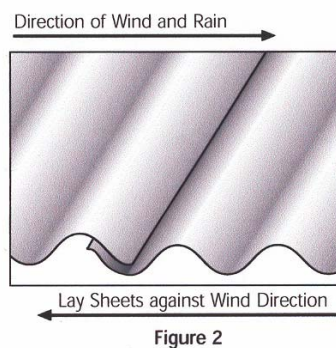
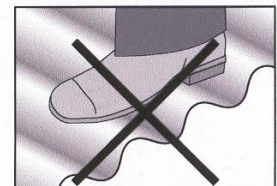
Figure 2

Warning! Do not step on the sheets between the purlins!

Figure 3

Width overlap (sheet edge): Minimum overlap: 7.88”

Minimum distance of 3.94” of each sheets edge from centerline of supporting purlins (line of screws).

Maximum overlap: 15.75”

Length overlap: 1/4 corrugation. The upper overlapping corrugation will be placed with the edge facing downward. Under certain conditions, it is recommended that 1-1/4 corrugations overlap should be implemented.

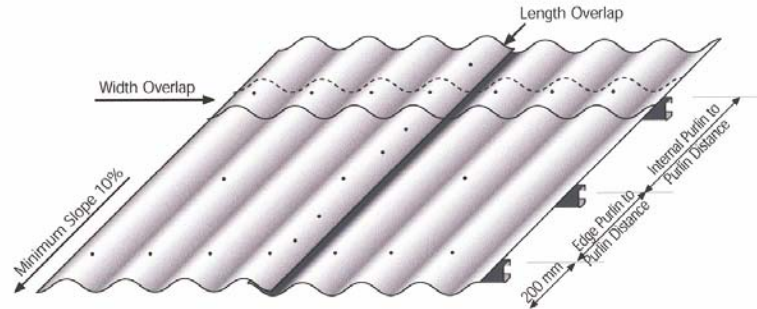

Figure 4

Roofs Edge: Sheets at the roof’s edge should extend over the edge by not more than 7.88”

Note: In case of total or partial replacement of existing Asbestos cladded roofs the minimal purlin overlap will be 2”.

Arching Radius:

1. When covering existing curved structures, it is possible to set the sheets on an existing arched framework so that they will arch within the range of elasticity of the sheets without inducing stress.
2. The minimum radius of the arch is 65.5’. However, H&F does not recommend covering new arched roofs with Asbestos profile sheets.

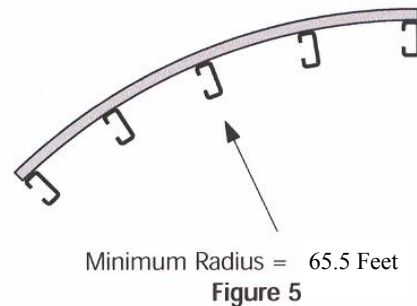

Figure 5

Roof Fastener Location:

1. A fastening screw should be inserted into at least every second corrugation crest at each internal purlin.
2. Along the edge purlin, the screws are to be inserted into each corrugation crests.
3. A hole must be pre - drilled into each screw location . The diameter of the hole must be .08” larger than that of the screw.
4. The screws should be tightened with an electric screw driver with an adjustable clutch, taking care not to over - tighten. Excess tightening may harm the sheet and cause premature failure.
5. Along the length of overlapping corrugations, it is recommended that sheet to sheet fasteners be attached between the purlins, at least one for every span. (See the section on “sheet to sheet” fasteners below)

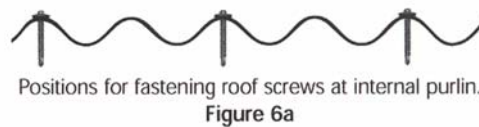

Figure 6a

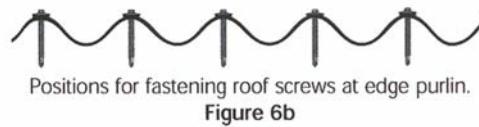

Figure 6b

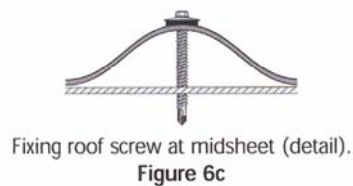

Figure 6c

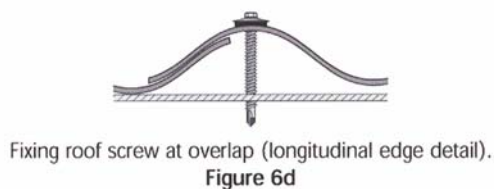
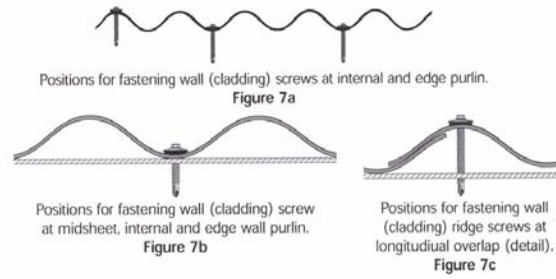

Figure 6d

Wall Fastener Location

1. A fastening screw must be inserted into every second corrugation valley, at each internal and edge purlin position.
2. Along the length of overlapping corrugations, the screw should be inserted through the upper panel at the corrugation crest over each purlin.
3. A hole must be pre - drilled into each screw location. The diameter of the hole must be .08” larger than that of the screw.



Screws, Washers, and Gaskets

1. **General Recommendations:** For optimal long - term maintenance free service, H&F strongly recommends the use of heavy - duty corrosion resistant screws, and special metal washers with profiled .16” (at least) thick EPDM rubber gaskets of .75” (crest) or .99” (valley) diameter, to fasten the sheets to the supporting structure and seal the fastener’s hole.
2. Use of self - tapping screws with pre - drilled holes or self - drilling screws is recommended. For wooden purlins a special wood screw should be used. (See fig 8e)
3. The screw placed into each corrugation crest should be .25” x 1.5”, or a #12 or 14 gage screw. Screws placed in a corrugation valley should be .25” x 1”. Each screw should be fitted with a conical corrosion resistant metal washer at least .04” thick and .75”/1” in diameter. Bonded to the underside of this washer is a special EPDM gasket of at least .16” thick. The screw should be tightened moderately without deforming the washer and rubber gasket or distorting the corrugation.
4. Special attention should be given to the insertion of the screws perpendicular to the material face. Oblique insertion could damage the sheet and/or result in leaks

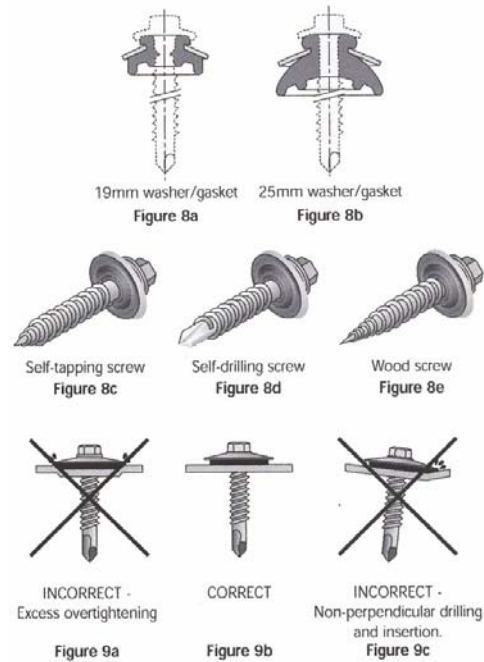

* H&F offers to supply, upon demand, the recommended fastening combinations mentioned above with the Asbestos

Sheet to Sheet Fasteners

Sheet to sheet fasteners are used to create a seal between overlapping sheets between purlins. When the slope of the roof is less than 15%, it is necessary to insert a fastener every 15.75”. Where the slope is greater than 15%, the spacing is every 19.69”. It is recommended to use 1/4” or 3/4” self - tapping screws **without the need for prior drilling of a hole**

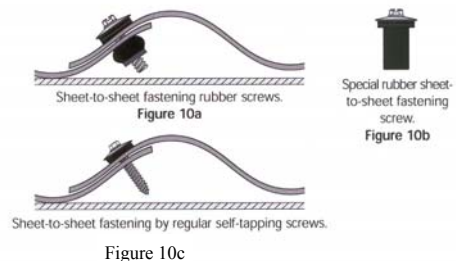

Handling and Storage

1. H&F corrugated sheets must be transported and stored horizontally on a flat, sturdy pallet whose dimensions are equal to or larger than the sheets themselves. The sheets should be secured and fastened to the pallet. It is possible to store sheets of smaller dimensions on top of larger sheets of the same type. (Never store sheets of larger dimensions on top of smaller sheets!) The sheets must be stored in a cool and shaded location.
2. Important: Never cover the pallet with, or place on the pallet, materials that are conductors of heat (e.g. metal, pipes, clear or dark objects).
3. In cases where it is necessary to store the pallet outdoors, cover it with a white opaque polyethylene sheet, cardboard, or any other material that does not absorb or conduct heat. The entire pallet must be covered.

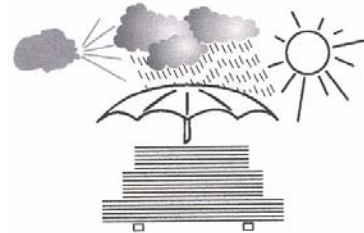

Storage of sheets.
Figure 11

Cutting

It is possible to cut H&F's corrugated sheets using a circular saw with small teeth, rotating at a high speed, taking care to advance the saw slowly. It is also possible to use a portable electric saw (Jig Saw) or sheet metal shears. In any case, it is important to support the sheet in the vicinity of the cut and clean away the dust and debris generated by cutting.

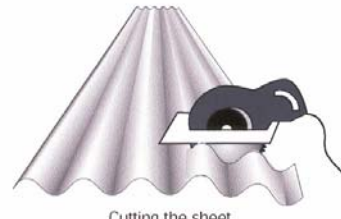

Cutting the sheet.
Figure 12

Drilling

1. Drilling should be carried out with a drill bit intended for metal. The hole diameter must be .08" greater than the diameter of the screw to be used. It is important to support the sheet in the vicinity where the sheet is being drilled. The dust generated by drilling must be cleared away before the insertion of the screw.
2. **Special attention should be given to drill all the required holes perpendicular to the face of the material.**

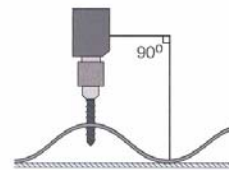

Drilling the sheet.
Figure 13

Chemical Resistance (compatible sealant and adhesive materials)

1. Asbestos 177 sheets are resistant to a variety of chemicals and exhibit limited resistance to a second group of chemicals. A third group of chemicals may attack and cause damage to the sheet. The degree of damage will depend on the severity of attack and time of exposure.
2. Choose only sealants and adhesives which are compatible with Polycarbonate.
3. **Use of sealants or adhesives not included in the recommended list must receive the Manufacturer's explicit approval. This can be obtained through your distributor. Use of materials not on the list, or which have not received the Manufacturer's explicit approval, may harm the sheet and will void all warranties and any responsibility of the manufacturer for the performance of Asbestos 177 sheets.**
4. Your local H&F distributor can provide additional information and forward materials for evaluation of their compatibility with Unitrex.

Sealing and Bonding

1. Silicone **Sealant** - H&F Manufacturing Corp. strongly recommends using either Dow Corning 3793 or Novasil S - 64 from Otto Chemie (white or transparent). For other materials, please consult your local sales representative.
2. Corrugated sealing closure strips should be used to prevent the entry of water, wind, insects or other small animals between installed sheets. A seal between the sheet and the edge purlin of the roof can be created using a sealing strip in the form of the profile. This is held in place by the same screw used to fasten the sheet to the purlin. The sealing strip should be manufactured from crosslinked polyethylene foam (XPE). See figure 14a
3. Sealing strip between overlapping sheets should be used where the pitch of the roof is less than 15%. Only Butyl rubber strips should be used. The strip should be placed between overlapping sheets along the length and width of the overlap at both edges. In cases where penetration of wind or fumes must be prevented, a sealing strip should be used irrespective of the slope of the roof. Wherever a sealing strip is inserted, a fastening sheet to sheet screw tightening the seal should be used.

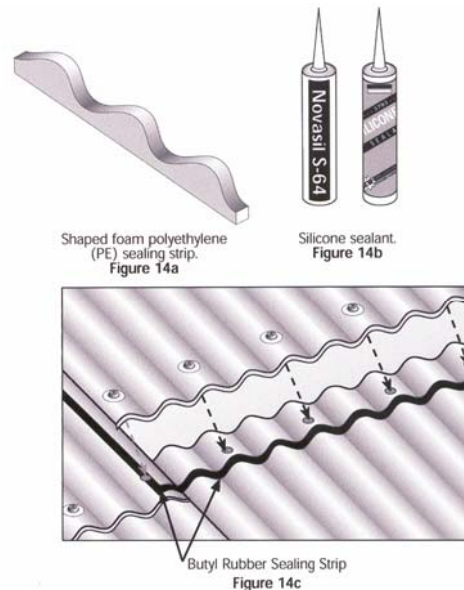

WARNING - Do not use materials which are not recommended by H&F Manufacturing Corp. Specifically, polyurethane foam should not be used to install either PHASE-2 PVC or Unitrex Polycarbonate. Contact with this material will render the sheets fragile. When in doubt, consult your H&F sales representative.

Finishing Accessories

Note: Asbestos 177 profile fixed angle ridge cap is available in 150 degree and 130 degree bends.

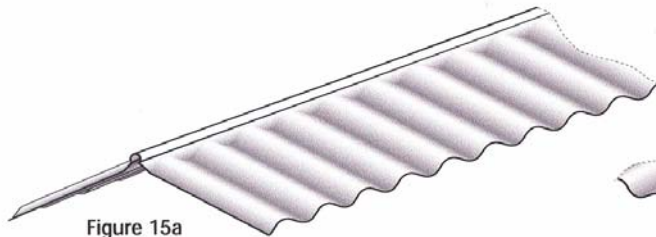

Asbestos 177 Profile Universal Ridge Cap with flexible angle

Dimensions:

7.5' x 6" x 6"

7.5' x 10" x 10"

Number of Corrugations: 12-1/4

Net Length: 7'3"

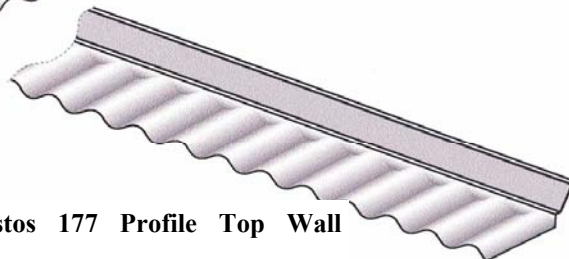

Asbestos 177 Profile Top Wall Trim

Dimensions:

7.5' x 6" x 2"

Number of Corrugations: 12-1/4"

Net Length: 7'3"

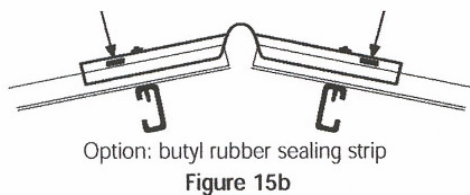

Option: butyl rubber sealing strip
Figure 15b

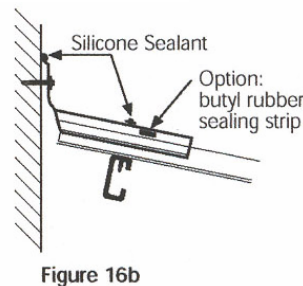

Figure 16b

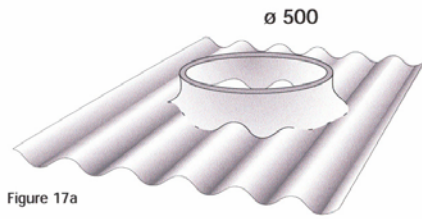

Figure 17a

Asbestos 177 Profile Air Vent Panel

Dimensions: 7' x 3'6"

Air Hole Diameter: 1 1/2'

Number of Corrugations: 5-1/2

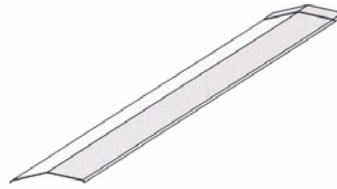

Figure 18a

Flat Ridge Cap 150 deg.

Dimensions:

8' x 8" x 8"

8' x 12" x 12"

Net Length: 7'10"



Cross section: American Profile Air Vent Panel
Figure 17b



Flat Ridge Cap 150°
Cross section: Sealing with shaped foam polyethylene strips
Figure 18b

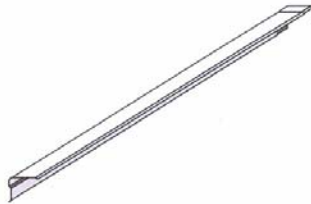

Figure 19a

Styled Gable Trim - 90 deg

7'5" x 6" x 5"

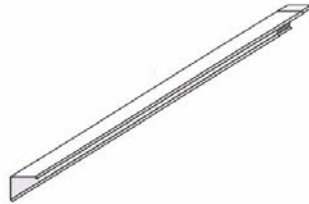

Figure 20a

Standard Side Gable Trim 90 deg

8' x 6" x 6"

8' x 8" x 8"



Figure 21a

Side Wall Trim 90 deg

8' x 2" x 6"

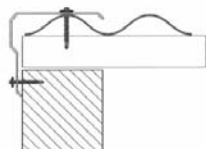

Cross section: Styled Gable Trim - 90°
Figure 19b

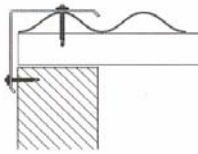

Cross section: Standard Side Gable Trim - 90°
Figure 20b

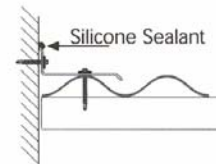

Cross section: Side Wall Trim - 90°
Figure 21b

All of the accessories depicted above are available from your H&F Manufacturing Corp Sales Representative. Flat ridge caps of various dimensions will be supplied upon request. Other sizes can be produced upon request and availability.

In as much as H & F Manufacturing Corporation's material has many approved uses, any non – standard uses should be tested by the user to determine its suitability. Proper installation techniques must be in accordance with H & F Manufacturing Corporation's procedures, and H & F will not be liable for damages due to improper installation. In accordance with our company's continual product development, you are advised to check with your H & F Manufacturing Corp. supplier to ensure that you have the most up-to-date information.